

ELT 01  
D GOK  
S -1.30

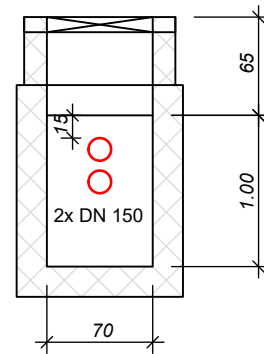
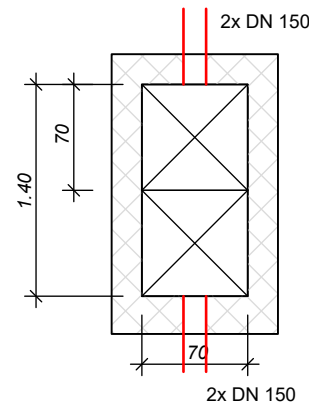
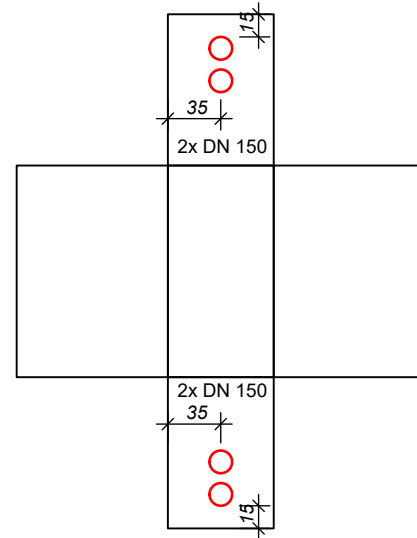

Index	Änderung	Datum	Name

<b>Planung</b>	 <b>RADEMACHER + PARTNER</b> <b>INGENIEURBERATUNG GMBH</b>	<b>Hauptsitz Hagen</b> 58095 Hagen   Böhmerstraße 2   02331 91588-0 irp@irp-hagen.de	
		Niederlassung Berlin 13509 Berlin   Breitenbachstraße 10 030 23578084	Niederlassung Hamburg 20095 Hamburg   Raboisen 38 0241 23578084

<b>Bauherr</b>	<b>Stadtwerke Remscheid GmbH</b> Neuenkamper Str. 81 -87 42855 Remscheid
----------------	--

# AUSFÜHRUNGSPLANUNG

<b>Projekt</b>	SBRS Remscheid H2O Badeparadies
----------------	------------------------------------

<b>Planinhalt</b>	Lageplan Planung
-------------------	------------------

gezeichnet	geprüft	Blattgröße	Maßstab	Plan Nr.
Je	Röder 04.11.2024	420x297	1:50	02

<b>Bauherr</b>	IRP
<b>Datum / Unterschrift</b>	Hagen, den